

**G168-216070 (21.6V 7.0A) 6S Li-Fe Battery Charger**

项目 Item	规格 Specification	备注 Remark
1.输入特性 Input		
额定输入电压 Rating input voltage	100~240Vac 50/60Hz	
输入电压范围 Input voltage range	90~264Vac	
额定输入电流 Rating input current	2.2Arms	Input:100V Output:Full load
功率因素 Power factor	PF>0.98	Input:115VAC Output:Full load
	PF>0.94	Input:230VAC Output:Full load
冲击电流 Inrush current	75A/230VAC (cold start)	
待机功耗 Standby power	1W	Input:115VAC&230VAC
最大输入功率 Max input power	183W	Input:100V Output:Full load
2.输出特性 Output		
空载输出电压 No load output voltage	DC21.6V ±1%	
输出电压范围 Output voltage range	DC15.0~21.6V	
适用电池 Suit with battery type	6S Li-Fe battery	
恒定电流 Charging current	7.0A ±7%	
恒定电压 Charging voltage	DC21.6V ±1%	
预充电流 Pre-charge	1.54A ±7%	电压≤18.0V预充
充电结束电流 Charge-end current	≤0.77A±10%	
定时器 Timer	-	
最大输出功率 Max output power	166.32W	
纹波电压 Ripple voltage	≤260mV	满载 Full load
充电指示灯 Charging LED	红灯闪 Red LED flashing	2Hz Error
	绿灯闪 Green LED flashing	待机 Idle
	红灯常亮 Red LED on	充电中 Charging
	绿灯常亮 Green LED on	充满 Full charged
输出短路保护 Shorted	有Yes	
输出反接保护 Reversed	有Yes	
效率 Efficiency	≥93%	满载 Full load @220V
3.环境要求 Environment		
工作温度 Operate temperature	-10 ~ +40℃	
工作湿度 Operate humidity	< +90%	相对湿度 Relative humidity
存储温度 Storage temperature	-40 ~ +70℃	
存储湿度 Storage humidity	0 ~ +95%	相对湿度 Relative humidity
冷却方式 Cooling	自然冷却 Natural	
抗振动 Vibration resistance	5MM/50HZ/600S	非运行状况 Non-operating condition
抗冲击 Impact resistance	1 meter drop test 3 times	非运行状况 Non-operating condition
4.结构 Mechanical		
重量 Weight	680g	
尺寸 Size	175X72X40MM	外壳尺寸Casing only
接线端子 Connector	按客户要求制定 Refer to order	
5.安全特性 Safety		
最大温升 Max. temperature rise	< 40℃ on casing	
安全认证 Safety approval	CE/SAA/FCC/CCC/cTUVus/CB/BS	
平均无故障时间 MTBF	30000H	
静电等级 ESD	8.0KV	
隔离耐电压 Hi-Pot Insulation	i/p to o/p: 3000V (1 min)	

CUSTOMER REV	REV	ZONE	DESCRIPTION	CHA BY/DATE	APP BY/DATE
--------------	-----	------	-------------	-------------	-------------

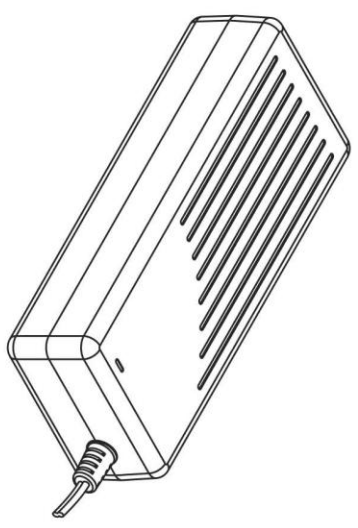
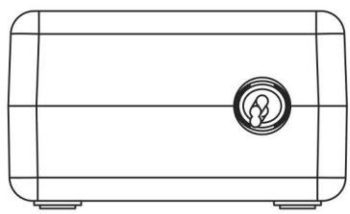
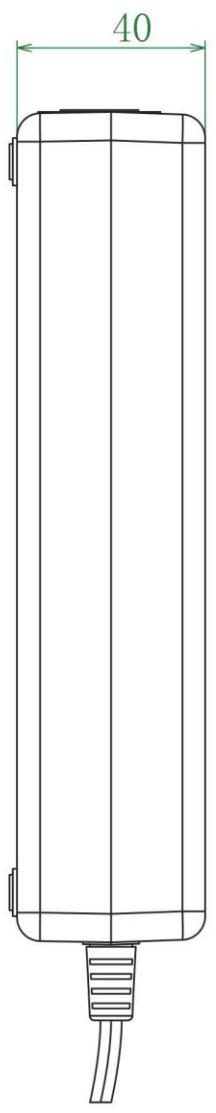
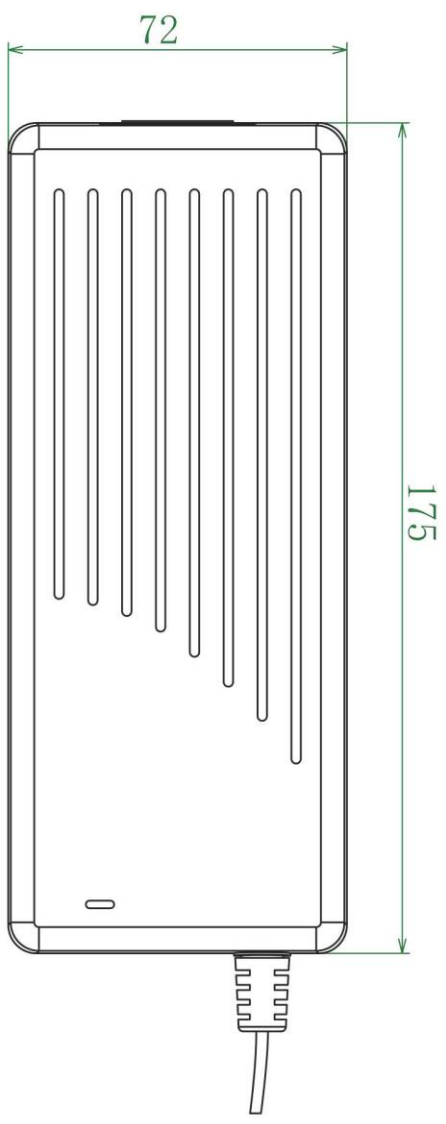

深圳市谷润数字电源有限公司

TITLE:		MATEL:	
MODEL:		G168W-XXXXXX	
DES BY:	CAD FILE:	UNIT : mm	WEIGHT:
CHECK BY:	COLOR:	Paper Size:A4	TEXTURE NO.
APP BY:	FINISH/TREATMENT:	SCALE: 1:1	DATE:

PART NO.:	
CUSTOMER P.N.:	

