

CUSTOMER \_\_\_\_\_

**SPECIFICATION FOR APPROVAL**

CUSTOMER PART NO \_\_\_\_\_

GDPT PART NO \_\_\_\_\_

DESCRIPTION PD.30W Type.C+USB.A USDATE 2022-12-16

MANUFACTURE			CUSTOMER APPROVAL
DESIGN	CHECKED	APPROVED	

SHENZHEN GREEN DIGITAL POWER TECH CO.,LTD

Address: #502,5F BLDG 01, Daxin Xinmei Industrial Park, 21 Gongchang Road,Guangming District, Shenzhen,Guangdong

**1 SCOPE****2 INPUT CHARACTERISTICS****3 OUTPUT CHARACTERISTICS****4 PROTECTION FUNCTION****5 ESD TEST****6 ENVIRONMENTAL REQUIREMENTS****7 MECHANICAL CHARACTERISTICS****8 SAFETY****9 EMC STANDARD****10 VOLUME****11 WEIGHT****12 OUTLOOK DRAWING****13 LABEL****14 PACKING**

## 1. SCOPE

The purpose of the document is to specify the functional requirements of PD.30W Type.C+USB.A switching power supply.

## 2. INPUT CHARACTERISTICS:

### 2.1 Input Voltage

Rated Input Voltage: 100-240Vac

Variable input voltage : 90V—264Vac

### 2.2 Input Current:

0.8A max when input rated voltage and output rated load.

### 2.3 Input Frequency

Rate Frequency:50/60Hz

Variation Frequency: 47-63Hz

### 2.4 In-rush Current:

30 A mps Max Cold start at 240Vac input ,with rated load and 25°C ambient.

### 2.5 AC leakage Current:

0.3mA Max .At 240Vac input

## 3. OUTPUT CHARACTERISTICS:

### 3.1 Rated Output Power :30W

### 3.2 Combined Load/line Regulation

USB-C Voltage	Min. Load	Max Load	Load Regulation	Unload output voltage
<u>+5V</u>	<u>0A</u>	<u>3.0A</u>	<u>4.75V-5.25V</u>	<u>4.75V-5.25V</u>
<u>+9V</u>	<u>0A</u>	<u>3.0A</u>	<u>8.55V-9.45V</u>	<u>8.55V-9.45V</u>
<u>+12V</u>	<u>0A</u>	<u>2.5A</u>	<u>11.4V-12.6V</u>	<u>11.4V-12.6V</u>
<u>+15V</u>	<u>0A</u>	<u>2.0A</u>	<u>14.25V-15.75V</u>	<u>14.25V-15.75V</u>
<u>+20V</u>	<u>0A</u>	<u>1.5A</u>	<u>19.0V-21.0V</u>	<u>19.0V-21.0V</u>
USB-A Voltage	Min. Load	Max Load	Load Regulation	Unload output voltage
<u>+5V</u>	<u>0A</u>	<u>3.0A</u>	<u>4.75V-5.25V</u>	<u>4.75V-5.25V</u>
<u>+9V</u>	<u>0A</u>	<u>2.0A</u>	<u>8.55V-9.45V</u>	<u>8.55V-9.45V</u>
<u>+12V</u>	<u>0A</u>	<u>1.5A</u>	<u>11.4V-12.6V</u>	<u>11.4V-12.6V</u>

USB-A+USB-C:5V=3A PPS:3.3V-11V=3A PPS:3.3V-16V=2A

### 3.3 Efficiency:

86.95%Min.at 100/240Vac input and output rated .Load.

### 3.4 Unload standby Power: 0.1W Max

### 3.5 Ripple And Noise

Under Rated voltage and nominal load ,The ripple and noise are as follows when measure with Max Bandwidth of20MHz and parallel 47UF/0.1, crossed connected at testing point.

USB-C Voltage	Current	Ripple And Noise(Max)
<u>+5V</u>	<u>3000mA</u>	<u>200mVp-p</u>
<u>+9V</u>	<u>3000mA</u>	<u>200mVp-p</u>
<u>+12V</u>	<u>2500mA</u>	<u>200mVp-p</u>
<u>+15V</u>	<u>2000mA</u>	<u>200mVp-p</u>
<u>+20V</u>	<u>1500mA</u>	<u>200mVp-p</u>

USB-A Voltage	Current	Ripple And Noise(Max)
<u>+5V</u>	<u>3000mA</u>	<u>200mVp-p</u>
<u>+9V</u>	<u>2000mA</u>	<u>200mVp-p</u>
<u>+12V</u>	<u>1500mA</u>	<u>200mVp-p</u>

### 3.6 Turn On Delay Time:

3 second Max .At 100Vac input and output Max. Load

### 3.7 Rise Time:

100ms Max. At 100Vac input and output Max. Load

### 3.8 Hold Up Time :

5ms Min.at100Vac input and output Max .Load.

### 3.9 Overshoot:

10% Max. When power supply on or turn off.

## 4. PROTECTION FUNCTION:

### 4.1 Short circuit protection:

The Power Supply will be auto recovered when short circuit faults remove.

#### 4.2 Over current Protection:

The power supply will auto protected when output current over  $\geq 110\%$  rate current.

#### 4.3 Over Voltage Protection:

The power supply will auto recovered when the voltage over / rate voltage.

### 5. ESD TEST

EN55024, EN61000-4-2

Test Criteria: EN55024, EN61000-4-2

Air discharge :  $\pm 8\text{KV}$

Contact discharge:  $\pm 4\text{KV}$

Performance Criteria: B

### 6. ENVIRONMENTAL REQUIREMENTS

#### 6.1 Operating Temperature

$0^{\circ}\text{C}$  to  $+40^{\circ}\text{C}$  ,Full Load, Normal Operation.

#### 6.2 Storage temperature

With enclosure:  $-10^{\circ}\text{C}$  to  $+55^{\circ}\text{C}$

#### 6.3 Relative Humidity:

$5\%(0^{\circ}\text{C})\sim 90\%(40^{\circ}\text{C})$  72h Full Load , Normal operating.

#### 6.4 Vibration

##### 6.4.1 Operating: IEC 721-3-3 3M3

$5\sim 9\text{Hz}$ ,  $A=1.5\text{mm}$

( $9\sim 200\text{Hz}$ , Acceleration  $5\text{m/s}^2$ )

##### 6.4.2. Transportation

IEC 721-3-2 2M2

$5\sim 9\text{Hz}$ ,  $A=3.5\text{mm}$

$9\sim 200\text{Hz}$  , Acceleration= $5\text{ m/s}^2$

$200\sim 500\text{Hz}$  , acceleration= $15\text{ m/s}^2$

## 6.4.3. Axes,10 cycles per axis :

No permanent damage occur during testing.

The product has to restore to its original situation after power off/on

No permanent damage occur during testing.

**7. MECHANICAL CHARACTERISTICS**

## 7.1 Dropping Testing ,

The product to be dropped from 1 meter height to a concrete floor no breakage.

**8. SAFETY STANDARD**

## 8.1 IEC62368, EN62368, UL62368, GB4943。

Safety Accord with IEC62368, EN62368, UL62368, GB4943。

## 8.2 DIELECTRIC STRENGTH Hi-Pot

Primary to secondary, 3000Vac/10mA/60s.

## 8.3 Insulation resistance:

Primary to secondary :10M $\Omega$  Min at 500V DC

## 8.4 Surge immunity with :

EN61000-4-5 1.2/50(8/20)US

**9. EMC STANDARD**

EMC---EN55022/EN55024/GB/T9254-2008 GB/T13837-2012

**10. VOLUME: L<sub>mm</sub> × W<sub>mm</sub> × H<sub>mm</sub>**

L30.6mm × W30.6mm × H47.6mm

**11. WEIGHT: 45.70g**

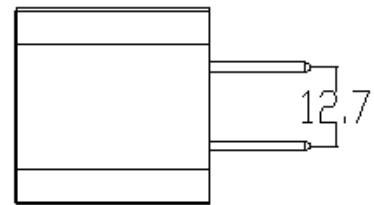
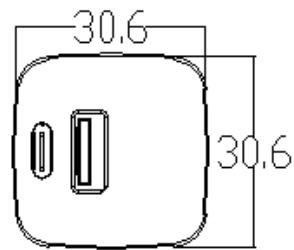
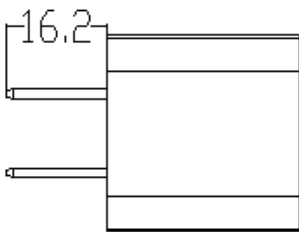
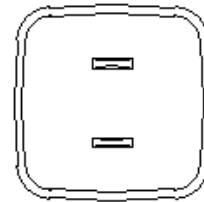
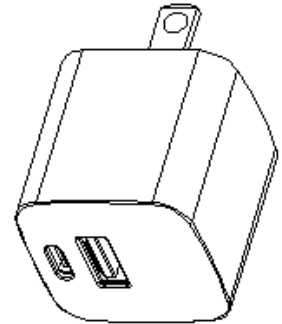
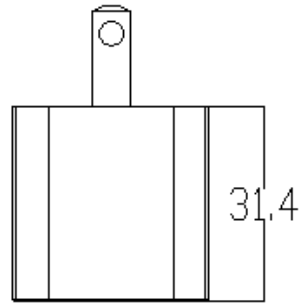
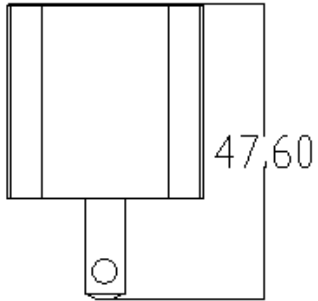
**12. OUTLOOK DRAWING (Common difference:  $\pm 0.5\text{mm}$ )**

**13. LABEL****AC CHARGER**

INPUT:100-240V~50/60Hz 0.8A Max

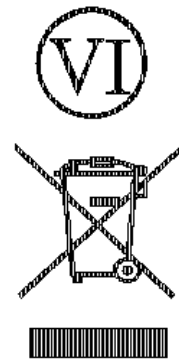
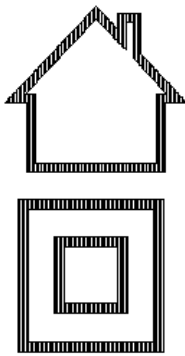
USB-C : 5V $\overline{\text{---}}$ 3A 9V $\overline{\text{---}}$ 3A 12V $\overline{\text{---}}$ 2.5A 15V $\overline{\text{---}}$ 2A  
20V $\overline{\text{---}}$ 1.5AUSB-A : 5V $\overline{\text{---}}$ 3A 9V $\overline{\text{---}}$ 2A 12V $\overline{\text{---}}$ 1.5AUSB-A+USB-C :5V $\overline{\text{---}}$ 3APPS: 3.3V-11V $\overline{\text{---}}$ 3A PPS: 3.3V-16V $\overline{\text{---}}$ 2A

CONFORMS TO UL STD.62368-1

No.62368-1

CERTIFIED TO CSA STD.C22.2

MADE IN CHINA 2212

**30** W**Note:**

1. Laser engraved nameplate

If the lable on the special requirements, please return the book to recognize when marked



14. PACKING

PE-LD 04

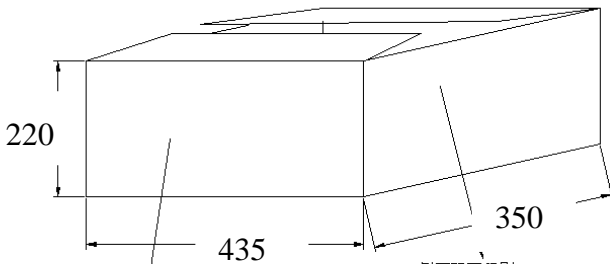
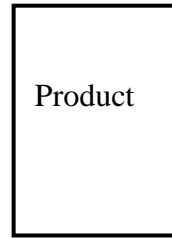
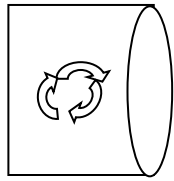

前后双面印刷  
MODEL:  
PART NO:  
QTY:

侧面双面印刷  
↑↑↑ 5  
POWER PRONIC  
C/NO:

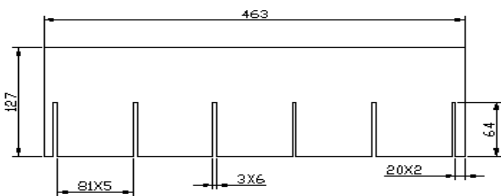
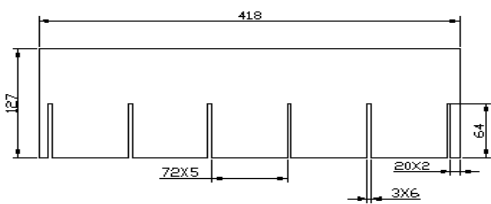

NOTE:

- 1. 100PCS Per carton, Divided into 2floor.  
Material A=A
- 2. PE bag size: 160X112MM , With the environmental protection symbol.