

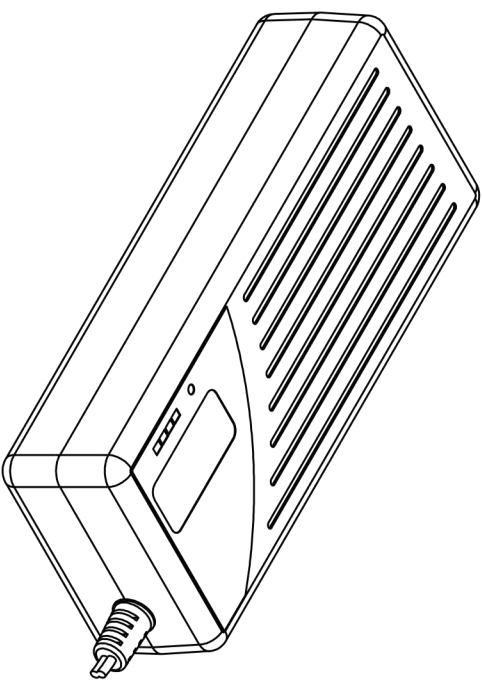

G100-48A 55.2V 1.5A Pb-Acid Battery Charger		
Item	Specification	Remark
1. Input		
Rating input voltage	100~240Vac 50/60Hz	
Input voltage range	90~264Vac	
Rating input current	1.5Arms	Input:100V Output:Full load
Max input power	100W	Input:100V Output:Full load
2. Output		
No load output voltage	DC58.8V	
Output voltage range	DC40.0~58.8V	
Suit with battery type	48V Pb-Acid battery	
Charging current	1.5A \pm 10%	
Charging voltage	DC58.8V \pm 1.2V	
Floating charge voltage	DC 52.8V-55.2V	
Charge-end current	0.3A \pm 0.1A	
Timer	10	
Max output power	88.2W	
Ripple voltage	552mV	Full load
Power LED	Red	Power on
Charging LED	All off	No battery
	All on	Full charge
	All flash	Error
	Flashing one by one	Charging
Shorted	Yes	
Reversed	Yes	
Efficiency	87%	Full load @220V
3. Environment		
Operate temperature	-10 ~ +40	
Operate humidity	< +90%	Relative humidity
Storage temperature	-40 ~ +70	
Storage humidity	0 ~ +95%	Relative humidity
Cooling	Natural	
Vibration resistance	5MM/50HZ/600S	Non-operating condition
Impact resistance	1 meter drop test 3 times	Non-operating condition
4. Mechanical		
Weight	400g	
Size	170X70X41MM	Casing only
Connector	Refer to order	
5. Safety		
Max. temperature rise	< 40 on casing	
Safety approval	CE/SAA/FCC/CCC	
MTBF	30000H	
ESD	8.0KV	
Hi-Pot Insulation	i/p to o/p: 3000V (1 min)	

CUSTOMER REV	REV	ZONE	DESCRIPTION	CHA BY/DATE	APP BY/DATE

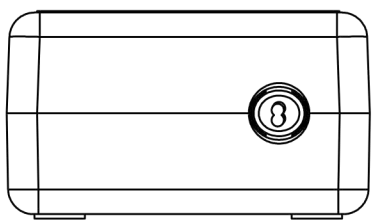
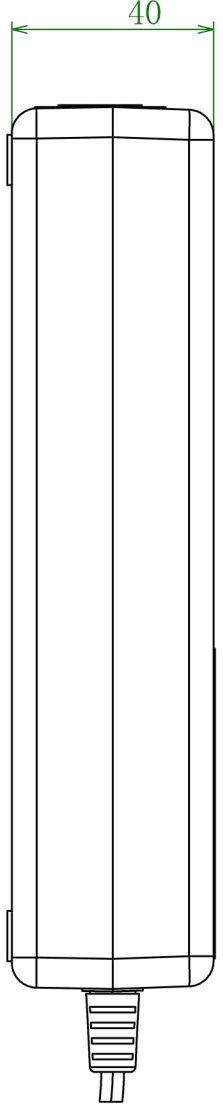
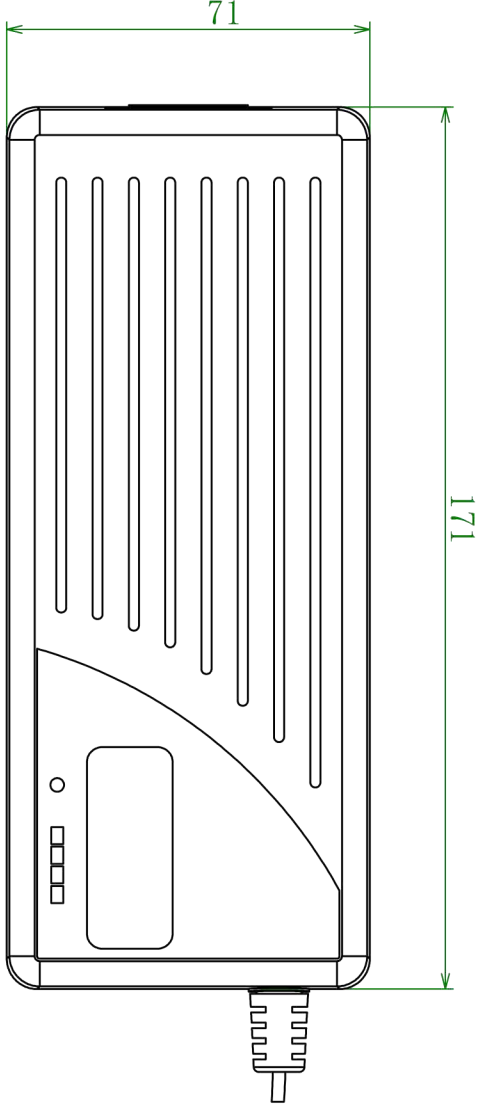

深圳市谷润数字电源有限公司

TITLE: G100W

MODEL: MATL: WEIGHT:

DES BY: CAD FILE: UNIT: mm TEXTURE NO.

CHECK BY: COLOR: Paper Size:A4 SCALE: **Fit**

APP BY: FINISH/TREATMENT: DATE:

PART NO.:	CUSTOMER P/N: