

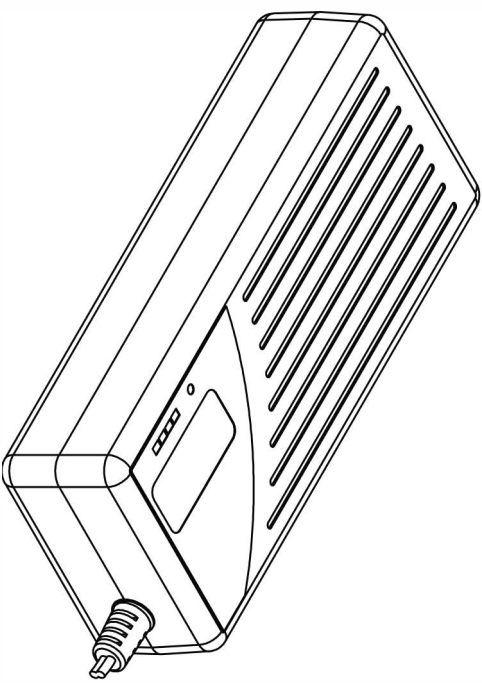

<b>G100-24L (29.4V 2.8A) 7S Li-ion Battery Charger</b>		
<b>Item</b>	<b>Specification</b>	<b>Remark</b>
<b>1.Input</b>		
Rating input voltage	100~240Vac 50/60Hz	
Input voltage range	90~264Vac	
Rating input current	1.5Arms	Input:100V Output:Full load
Max input power	100W	Input:100V Output:Full load
<b>2.Output</b>		
No load output voltage	DC29.4V	
Output voltage range	DC17.5~29.4V	
Suit with battery type	7S Li-ion battery	
Charging current	2.8A ±10%	
Charging voltage	DC29.4V ±0.35V	
Pre-charge	0.4±0.1A	Voltage≤21.0V Precharge
Charge-end current	≤0.2A±0.05A	
Timer	-	
Max output power	82.32W	
Ripple voltage	≤294mV	Full load
Power LED	Red	Power on
Charging LED	All off	No battery
	All on	Full charge
	All flash	Error
	Flashing one by one	Charging
Shorted	Yes	
Reversed	Yes	
Efficiency	≥87%	Full load @220V
<b>3.Environment</b>		
Operate temperature	-10 ~ +40°C	
Operate humidity	< +90%	Relative humidity
Storage temperature	-40 ~ +70°C	
Storage humidity	0 ~ +95%	Relative humidity
Cooling	Natural	
Vibration resistance	5MM/50HZ/600S	Non-operating condition
Impact resistance	1 meter drop test 3 times	Non-operating condition
<b>4.Mechanical</b>		
Weight	400g	
Size	175X72X40MM	Casing only
Connector	Refer to order	
<b>5.Safety</b>		
Max. temperature rise	< 40°C on casing	
Safety approval	CE/cTUVus/CCC/PSE	
MTBF	30000H	
ESD	8.0KV	
Hi-Pot Insulation	i/p to o/p: 3000V (1 min)	

CUSTOMER REV	REV	ZONE	DESCRIPTION	CHA BY/DATE	APP BY/DATE

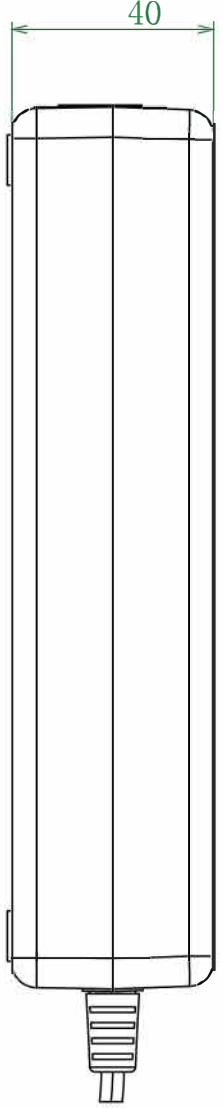
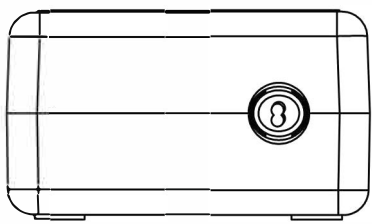
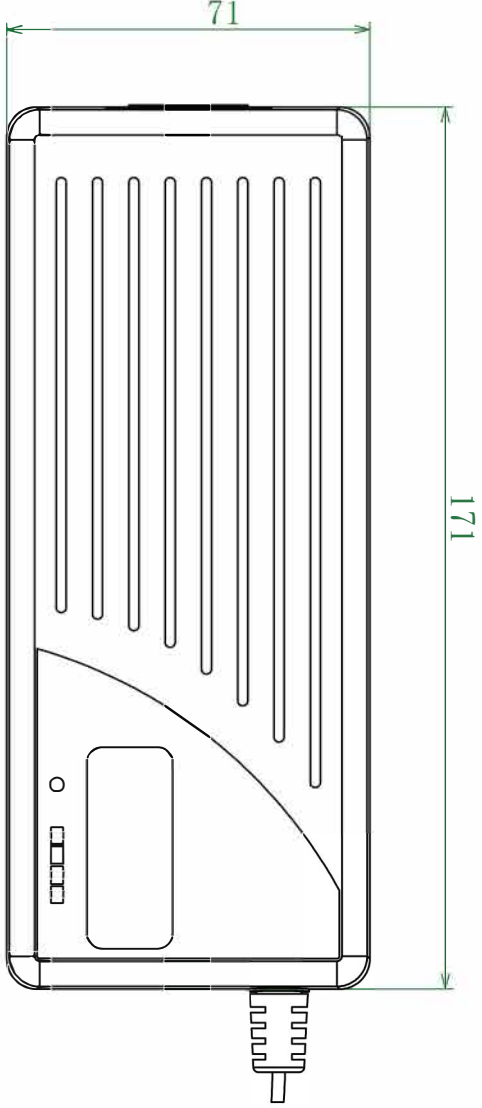

Shenzhen Green Digital Power-Tech CO., LTD

TITLE: G100W

MODEL: MATE: WEIGHT:

DES BY: CAD FILE: UNIT: mm TEXTURE NO

CHECK BY: COLOR: Paper Size: A4 SCALE: Ft

APP BY: FINISH/TREATMENT: DATE:

PART NO.:  
CUSTOMER P/N:

